

## WHEELS AND TIRES

<b>OUTLINE</b> .....	12- 2
SPECIFICATIONS .....	12- 2
<b>TROUBLESHOOTING GUIDE</b> .....	12- 2
<b>WHEELS AND TIRES</b> .....	12- 3
INFLATION OF TIRES .....	12- 3
TIRE ROTATION .....	12- 3
WHEEL AND TIRE RUN OUT .....	12- 3
WHEEL BALANCING .....	12- 3



# 12 OUTLINE, TROUBLESHOOTING GUIDE

## OUTLINE

### SPECIFICATIONS

Size	Offset	Wheels		Tires	
		Diameter of pitch circle	Material	Size	
5½JJ	45 mm (1.772 in)	114.3 mm (4.5 in)	Steel or aluminum	P205/60 HR14 205/60 R14 87H	

## TROUBLESHOOTING GUIDE

Problem	Possible Cause	Remedy	Page
<b>Excessive or irregular tire wear</b>	Incorrect tire pressure Unbalanced wheel(s) Tires not rotated correctly Severe driving Improper toe-in adjustment Poor braking function	Adjust Adjust Rotate properly Advise driver Adjust Adjust	
<b>Premature tire wear</b>	Excessive tire pressure High-speed driving with low tire pressure	Adjust Adjust	
<b>Tire squeal</b>	Incorrect tire pressure Tire deterioration	Adjust Replace	
<b>Road noise or body vibration</b>	Insufficient tire pressure Unbalanced wheel(s) Deformed wheel(s) or tire(s) Irregular tire wear	Adjust Adjust Repair or replace Replace	12-3
<b>Steering wheel vibration</b>	Irregular tire wear Left and right tread depths are different Deformed or unbalanced wheel(s) Deformed tire(s) Unequal tire pressures Loose lug nuts	Replace Replace Replace or adjust Replace Adjust Tighten	
<b>Uneven (one-sided) braking</b>	Unequal tire pressures	Adjust Replace or adjust	12-3
<b>Steering wheel doesn't return properly, or pulls to one side (pulls to either left or right while vehicle is moving on a level road surface)</b>	Incorrect tire pressure Irregular tire wear (left and right are different) Unequal tire pressures Different types or brands of tires mixed (left/right) Improperly tightened lug nuts	Adjust Replace Adjust Replace Tighten	
<b>General driving instability</b>	Unequal tire pressures Deformed or unbalanced wheel(s) Loose lug nuts	Adjust Tighten Replace	12-3
<b>Excessive steering wheel play</b>	Loose lug nuts Adjusted front wheel bearing preload	Adjust Tighten	

47U12X-015

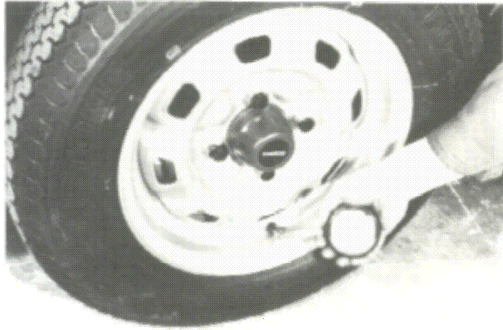

47U12X-001

## WHEELS AND TIRES

### INFLATION OF TIRES

Check the inflation pressure with a reliable gauge when tires are cold. The recommended cold tire inflation pressure are as follows.

Tire size	Front	Rear
185/70HR 13	190 Kpa (27 psi)	190 Kpa (27 psi)
165 HR 13	190 Kpa (27 psi)	190 Kpa (27 psi)
T135/70D 13	420 Kpa (60 psi)	420 Kpa (60 psi)
205/60 VR 14	200 Kpa (28 psi)	200 Kpa (28 psi)

Snow tires should always be inflated 4 psi above the recommended inflation pressures shown on the table. **Do not use** snow chains with temporary spare tire.

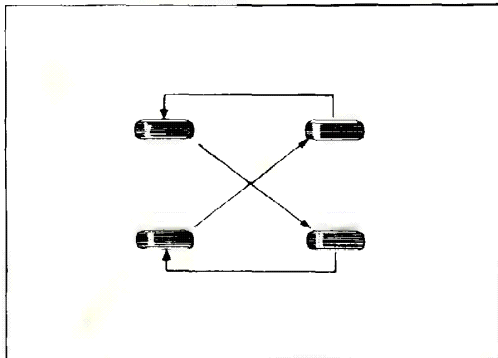

47U12X-002

### TIRE ROTATION

To equalize wear and make a set of tires last longer, it is recommended that the tires be rotated periodically, as shown in figure.

When rotating the tires, check for signs of abnormal wear or bulging any stone, nail, glass, etc. should be removed.

#### Tightening torque of wheel bolt:

**90 ~ 120 N-m (65 ~ 87 ft-lb)**

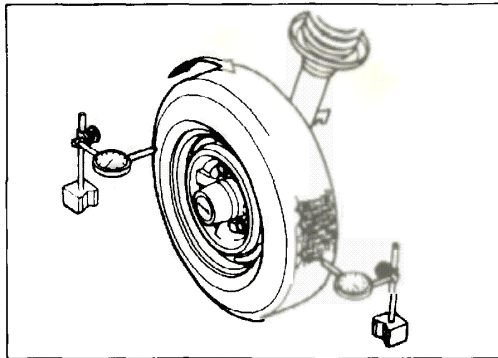

47U12X-003

### WHEEL AND TIRE RUN-OUT

Wheel and tires should be measured for both radial and lateral run-out.

To measure the radial run-out, apply a dial indicator against the center rib of the tire tread and rotate the wheel slowly.

**Run-out limit: 2.0 mm (0.08 in)**

To measure the lateral run-out, position a dial indicator against the side of the tire.

**Run-out limit: 2.5 mm (0.10 in)**

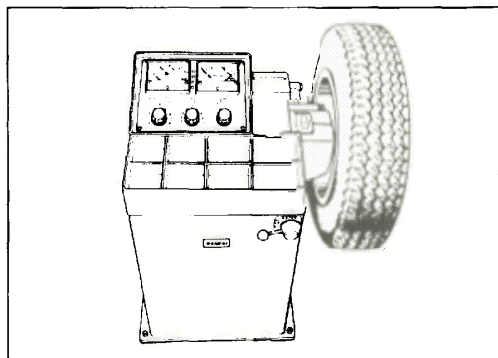

47U12X-004

### WHEEL BALANCING

The allowable unbalance is less than 20 g (0.71 oz) at the rim.

Excessive wheel unbalance causes shimmy at high speed.

If unbalance exceeds the specification or when a tire is disassembled for repair, the tire and wheel assembly should be statically and dynamically balanced with a wheel balancer in accordance with the manufacturers instructions.